

# Air Table

### Customer Information

Contact Name: \_\_\_\_\_

Customer Address: \_\_\_\_\_

Contact Email: \_\_\_\_\_

Customer Name: \_\_\_\_\_

Date: \_\_\_\_\_

Phone: \_\_\_\_\_

### Product Information

Part width: min" \_\_\_\_\_ / max" \_\_\_\_\_

Part length: min" \_\_\_\_\_ / max" \_\_\_\_\_

Part Thickness: min" \_\_\_\_\_ / max" \_\_\_\_\_

Part Weight: min \_\_\_\_\_ / max \_\_\_\_\_

### Available Options (Highlight if Interested)

- |                                      |                                  |
|--------------------------------------|----------------------------------|
| 2" Pneumatic Top Lift                | Felt Liner Top (Perf Only)       |
| Hydraulic Scissor Lift Base          | Perimeter Urethane Roller        |
| Perimeter Brush                      | Top Only/Remote Blower           |
| Lift-N-Slide<br>(Manual & Automatic) | Manual Crank Scissor Lift<br>Top |

### Machine Power Requirements

Phase 1 or 3: \_\_\_\_\_

Voltage 220 / 240 or 480: \_\_\_\_\_

Diffused Style Top

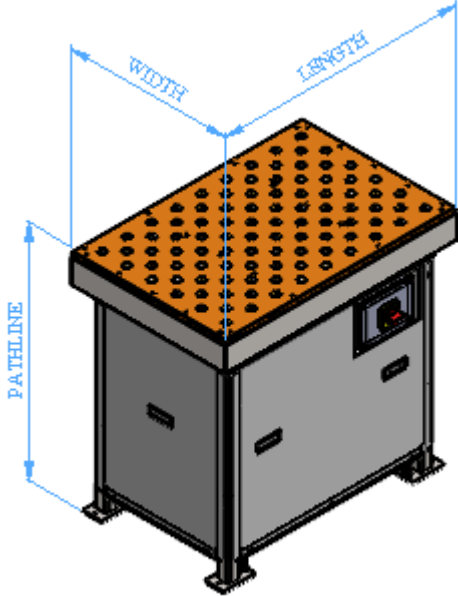

Perforated Style Top

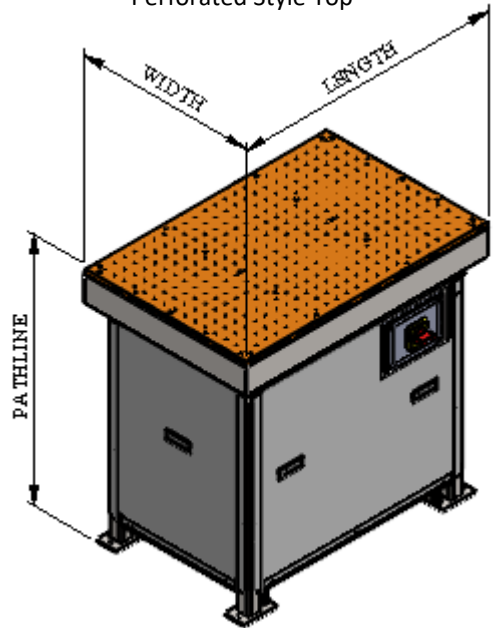

### Special Requirements

Notes: \_\_\_\_\_

\_\_\_\_\_  
\_\_\_\_\_

Address: 414 S. Cherokee St

Girard, Ks 66743

Phone: 620-724-6220